



G-E HAM NEWS

Copyright 1955, by General Electric Company

TUBE DEPARTMENT
GENERAL ELECTRIC
Schenectady 5, N. Y.

NOVEMBER-DECEMBER, 1955

VOL. 10—NO. 6

A 6-METER SPECTACULAR—Part III "BONUS 100-WATT" TRANSMITTER

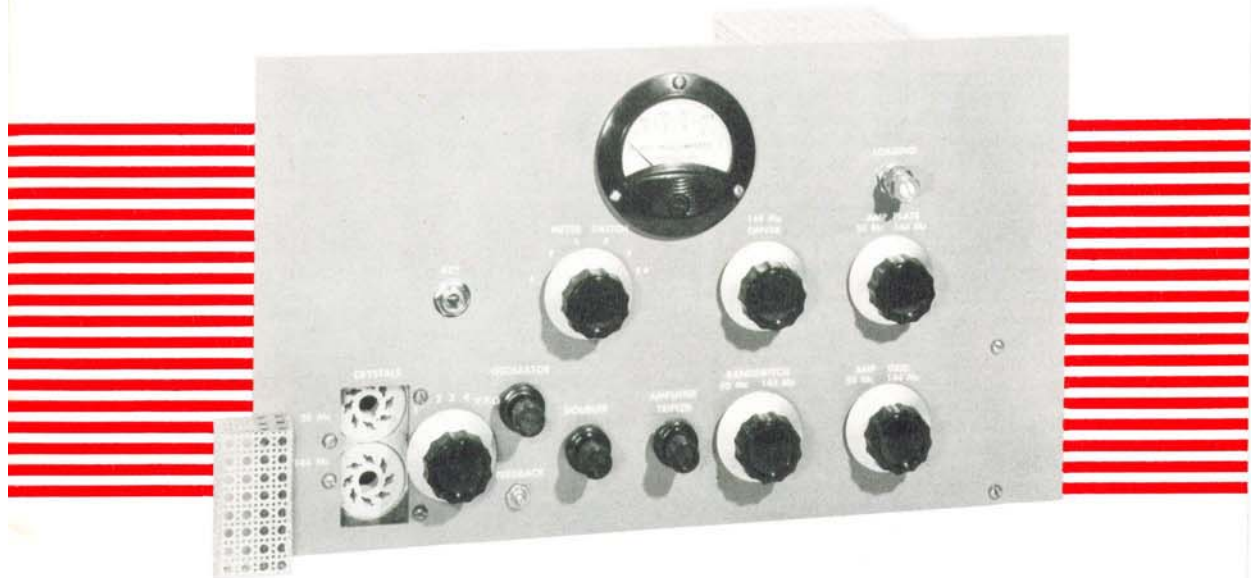

Almost any dictionary will tell you that the word "BONUS" means, "Something given in addition to what is usual." By employing an extra tube, plus a few dual-range tank circuits and parts, this "Bonus 100-watt Transmitter," developed by W2ZHI for Part III of the G-E HAM NEWS 6-meter Spectacular, also puts you on 2 meters with the same power. Front panel controls for all normal tuning, circuit metering, crystal changing and switching, permit this rig to be buttoned up in a complete TVI shield if necessary.

—*Lighthouse Larry*

CONTENTS

Bonus 100-watt Transmitter	page 2
Sweeping the Spectrum	page 7
"Operation Crystal"	page 8

BONUS 100-WATT TRANSMITTER

Most amateur transmitters for 50 or 144 megacycles follow the same frequency range pattern in the first stages of the exciter. Why build two separate units, practically identical, when one exciter can handle both jobs?

And while we're at it, why not design the final amplifier to cover both bands? Of course, the amplifier tube selected would have to be one which works efficiently on the 144-megacycle band, such as the GL-829B. This tube can be run from relatively inexpensive power supplies and plate modulators. Several commercially built 3.5- to 30-megacycle amateur transmitters are marketed in this 100-watt power class. If you are the owner of one of these rigs, you can *borrow* plate and modulation power from it for this "Bonus 100-watt Transmitter." This unit also makes a good exciter for that future one-kilowatt amplifier to help extend your VHF working range after you have installed a rotary beam antenna and a low noise receiver for each band.

CIRCUIT DETAILS

After glancing at the schematic circuit diagram, shown in Fig. 1, you may think that Lighthouse Larry has fallen into a rut by using this pi-network overtone crystal oscillator circuit for the third time in as many issues. But—that's no rut—that's just a good versatile oscillator circuit. One half of a 12AT7 twin-triode oscillates from 24 to 27 megacycles by tuning C_1 . Mica padder capacitor C_2 controls the feedback to any one of four 8.000 to 8.222 or 8.334 to 9.000 megacycle crystals. This permits your local network or calling frequency and one other frequency to be covered in each band. The fifth position on crystal selector switch S_1 permits output from an external 8- or 12-megacycle variable frequency oscillator connected to J_1 to be fed into the grid of the oscillator tube, which then operates as a tripler or doubler, respectively.

Tank circuit L_2 - C_3 in the plate circuit of the other section of the 12AT7 doubles frequency to the 48-54-megacycle range. A two-band pi-network circuit appears in the plate circuit of the 5763 amplifier-tripler stage. On 144 megacycles, bandswitch S_2 (shown in the 144-megacycle position) connects the output side of coil L_3 to loading capacitor C_7 in the grid circuit of the GL-2E26 144-megacycle amplifier. When S_2 is placed in the 50-megacycle position, L_4 is placed in series with L_3 and loading capacitor C_6 matches the output of this larger pi-network to the amplifier link coaxial cable. This circuit is tuned on both bands with C_4 . Mica padder capacitor C_5 and the lead to screen grid pin 6 on the 5763 tube socket form a series-resonant circuit to stabilize this stage when working it as a 50-megacycle amplifier.

A series-tuned 144-megacycle tank circuit in the plate circuit of the GL-2E26 consists of C_9 and L_5 . To insure stability, variable capacitor C_8 and its connecting leads provide a series-tuned screen grid neutralization circuit for this stage. This tube is disabled by removing screen voltage and grid excitation when S_2 is in the 50-megacycle position. The bandswitch also increases the grid circuit resistance of the 5763 tripler stage in the 144-megacycle position and transfers the RG-58/U coaxial cable from link L_8 in the grid circuit of the GL-829B amplifier to either the 50-megacycle output from the 5763 or the 144-megacycle output from L_6 in the plate circuit of the GL-2E26 stage. Enough cathode bias is used on these stages to keep the plate dissipation within bounds when no excitation is present.

The problem of working the GL-829B stage on both 50 and 144 megacycles without bandswitches or plug-in coils was solved by using capacity-loaded half-wave-

length linear grid and plate tank circuits for 144 megacycles (L_9 and L_{12}). Then, small split coils (L_7 and L_{10}) were tapped onto the lines at the 144-megacycle RF ground point. The inductance of these coils was adjusted to resonate at 50 megacycles with the tube, circuit and tuning capacities. The rotor of plate circuit butterfly variable capacitor C_{11} is not grounded. Otherwise, the 0.030-inch air-gap with which this capacitor is supplied would not be sufficient to withstand positive plate modulation peaks with a 600-volt amplifier plate supply. Variable link coil L_{11} couples the transmitter output to a 50-ohm coaxial cable. A larger coil will be required if the transmitter feeds a 300-ohm line.

A combination clamp-tube and keying circuit in the screen of the GL-829B is formed by the 6V6-GT and OB2 tubes. When the GL-829B is drawing grid current, the 6V6-GT is biased to cut-off and screen current flows through the OB2. Lack of amplifier grid current because of no driving power or removing the grid bias from the 6V6-GT by opening keying circuit jack J_3 permits this tube to draw plate current.

The extra voltage drop through the 20,000-ohm adjustable screen resistor causes the OB2 voltage regulator tube to stop conducting. The GL-829B screen voltage then falls to zero, reducing the plate current to a very low value.

METERING CIRCUITS

In positions A to E, a 2-pole, 6-position rotary tap switch (S_3) connects a 0- to 1-milliammeter in series with a 2000-ohm resistor across shunting resistors placed in series with circuits where current metering is desired. This range meter now costs no more than those with larger current ratings and simplifies the selection of shunting resistors. The 400-ohm shunts in positions A and B provide a 5-milliamperere full scale reading for the 5763 and GL-2E26 grid currents. Position C measures up to 100 milliamperes full scale across the 20-ohm resistor in the GL-2E26 plate circuit. The GL-829B grid current is read in position D across a 100-ohm resistor. Two 16-ohm, 1-watt resistors in parallel provide a full scale meter reading of 250 milliamperes in the GL-829B plate circuit in position E.

In the sixth position F, the meter is placed in series with two 390,000-ohm, $\frac{1}{2}$ -watt resistors for measuring the amplifier plate supply up to 800 volts. This position could be changed to place the meter across a 20-ohm resistor in the 5763 plate supply lead to provide a 100-milliamperere full scale reading, if desired.

MECHANICAL DETAILS

The entire RF unit is mounted on an 8 x 12 x 3-inch deep aluminum chassis, drilled as shown in Fig. 2. The 8 x 14-inch cabinet panel and chassis front are drilled with matching holes. Location of most critical parts is marked on this illustration. The tuning controls for the exciter were mounted along the front edge of the chassis. Space was left at the right side for the GL-829B amplifier and associated tank circuits. The special septor socket (Johnson 122-101) used for this tube has provision for crossed No. 12 plastic insulated neutralizing wires to run from the grid connections through small holes in the ceramic wafer. They extend up the sides of the tube, forming one plate of capacitors C_N , with the tube plates forming the other. The $2\frac{3}{4}$ -inch diameter hole for this socket was made with a circle cutter. Or, it can also be "nibbled" out with a pair of small tin shears if a *starter* hole is first made with a socket punch.

Amplifier plate tuning capacitor C_{11} mounts on a $\frac{1}{4}$ -inch thick block of polystyrene or lucite 2 inches wide and $1\frac{3}{4}$ inches high. Three 6-32 x $\frac{1}{2}$ -inch deep

holes are drilled and tapped in this insulator for mounting screws which run up through the chassis or it can be fastened to a small piece of aluminum angle. The shorter lengths of copper tubing forming part of L_{12} lie in notches cut in the upper corners of this insulator. A right angle bend in the tubing permits the ends to connect to the stator terminals on C_{12} . The other ends of this tubing fasten to 8-32 x $3\frac{1}{4}$ -inch long threaded brass rods mounted on a pair of 1-inch high cone insulators. Lugs formed on the ends of 50-megacycle plate coil L_{10} slip on the threaded rods and fasten with 8-32 brass hex nuts above and below them. This mounting allows L_{10} to be positioned at the 144-megacycle RF ground point on the tank circuit. The longer tubing in L_{12} extends from the top of the threaded rods to

the heat radiating plate caps on the GL-829B through $\frac{3}{4}$ -inch long flexible strips made from 0.010-inch thick sheet copper flashing material. The metal-to-glass plate pin seals on the GL-829B may be cracked if the tubing is attached directly to the plate caps.

Output link coil L_{11} fastens to the rear of a 3-inch long, $\frac{1}{4}$ -inch diameter shaft and panel bearing assembly. A 6-32 x $\frac{3}{8}$ -inch deep hole is tapped in the end of the shaft for fastening the grounded side of the link. A shaft lock prevents the coupling from changing after adjustment. A box made from perforated sheet aluminum $3\frac{1}{2}$ inches wide, $4\frac{1}{2}$ inches high and 8 inches long encloses the amplifier plate circuit. Several 6-32 self-tapping screws fasten the shield to the back, top and side of the chassis. Inter-stage shielding made from

PARTS LIST

- C_1 —2.7–19.6-mmF variable (Johnson 20M11)
 $C_{2, 3, 6}$ —65–340-mmF mica padder (El Menco 303)
 C_3 —2.3–14.2-mmF variable (Johnson 15M11)
 C_4 —1.7–8.7-mmF variable (Johnson 9M11)
 C_7 —5.0–50-mmF mica trimmer
 C_8 —6–75-mmF variable (Johnson 75K10)
 C_9 —2.8–11-mmF variable (Johnson 10L15)
 C_{10} —4.3–26-mmF butterfly variable (Johnson 25LB15)
 C_{11} —2.8–10.5-mmF butterfly variable (Johnson 10LB15)
 $J_{1, 2}$ —chassis coaxial receptacle

- J_3 —3-conductor single closed circuit phone jack
 RFC_1 —1-mh, 100-ma (National R-50)
 $RFC_{2, 6}$ —7- μ h choke (Ohmite Z-50)
 $RFC_{3, 4, 5}$ —0.84- μ h choke (Ohmite Z-144)
 S_1 —1-pole, 5-position tap switch (Mallory 3215J)
 S_2 —6-pole, 2-position midget ceramic tap switch (Centralab PA-2019)
 S_3 —2-pole, 6-position tap switch (Mallory 3226J)
 T_1 —6.3-volt, 4.5-ampere filament transformer
 All capacitors in mmf are 600-volt disk ceramic, capacitors in mfd are 600-volt paper.
 All resistors $\frac{1}{2}$ -watt, $\pm 10\%$, unless otherwise specified.

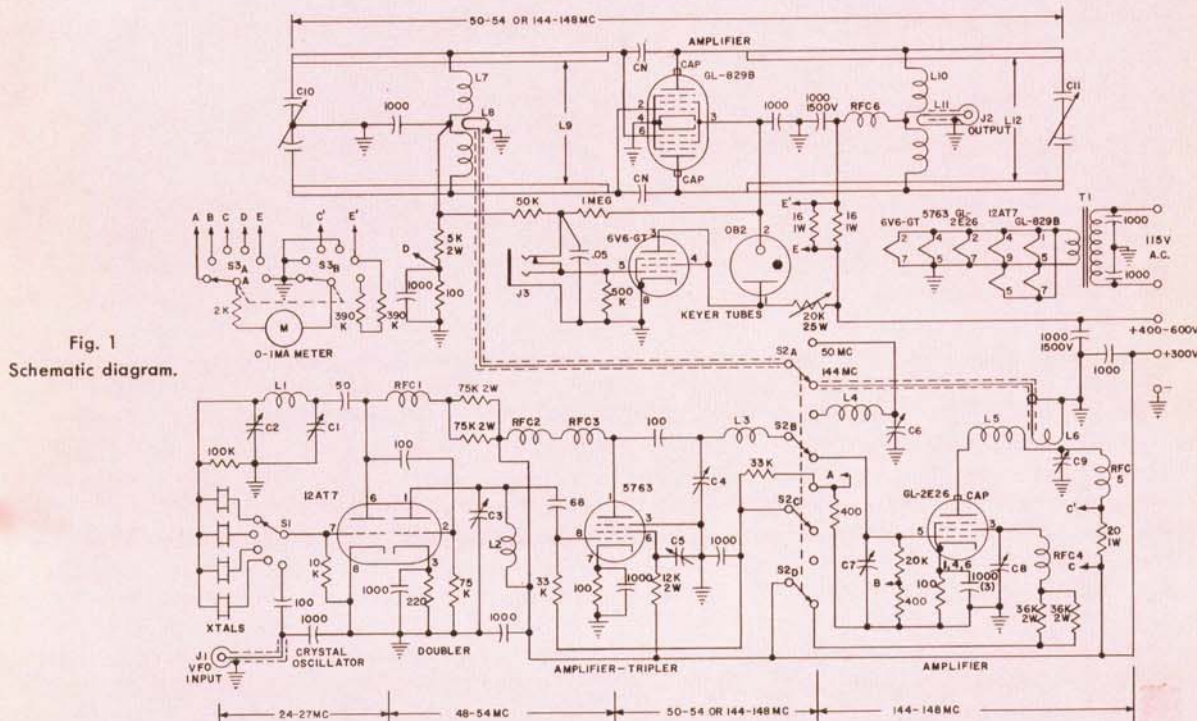

Fig. 1
Schematic diagram.

COIL TABLE

- NOTE: Coils L_1 , L_2 and L_4 made from B & W Miniductors, type 3007, $\frac{5}{8}$ -inch diameter, 16 turns per inch. L_1 —15 turns, L_2 and L_4 —5 turns.
 L_3 —4 turns, No. 16 solid wire, $\frac{1}{2}$ -inch diameter, $\frac{5}{8}$ -inch long.
 L_5 —4 turns, No. 12 solid wire, $\frac{1}{2}$ -inch diameter, $\frac{3}{4}$ -inch long.
 L_6 —1 turn loop, No. 12 plastic insulated solid wire, $\frac{1}{2}$ -inch diameter.
 L_7 —1 turn loop, No. 12 solid wire, 1-inch diameter with $\frac{3}{4}$ -inch leads.
 L_8 —1 turn loop No. 12 plastic insulated solid wire, $\frac{3}{4}$ -inch diameter, with a loop to fit a No. 8 screw on one end.

- L_9 —12-inch length of 300-ohm flat twinlead, tapped 4 inches from grid end by removing 1 inch of insulation and twisting the wires into $\frac{1}{2}$ -inch leads, $\frac{1}{2}$ -inch long leads formed at each end.
 L_{10} —8 turns, No. 10 solid wire, $\frac{3}{4}$ -inch diameter, formed into 2 4-turn coils, each $\frac{1}{2}$ -inch long with a $\frac{1}{4}$ -inch space in center. Loops to fit 8-32 screw spaced 2 inches, formed on each end.
 L_{11} —2 turns No. 12 plastic insulated solid wire, $\frac{1}{2}$ -inch diameter with a loop to fit a No. 6 screw on one end.
 L_{12} —4 lengths of $\frac{1}{4}$ -inch O.D. copper tubing, 2 each, 6 inches long and $5\frac{1}{4}$ inches long, with $\frac{1}{2}$ inch at each end flattened and drilled to clear a No. 8-32 screw. (See Construction Details.)

Fig. 4—Chassis top view. Shield box removed to show the GL-829B tank circuit.

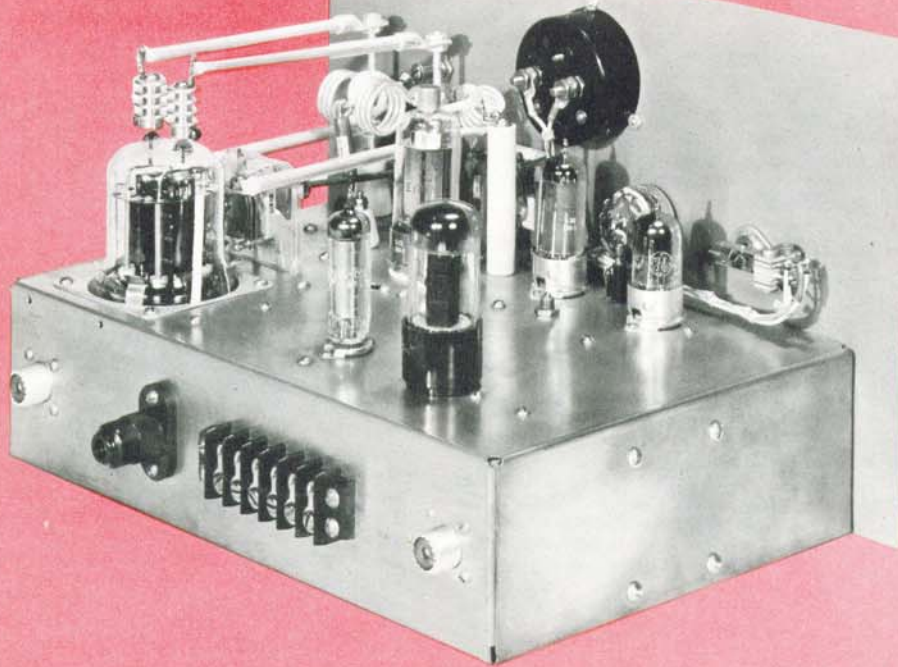
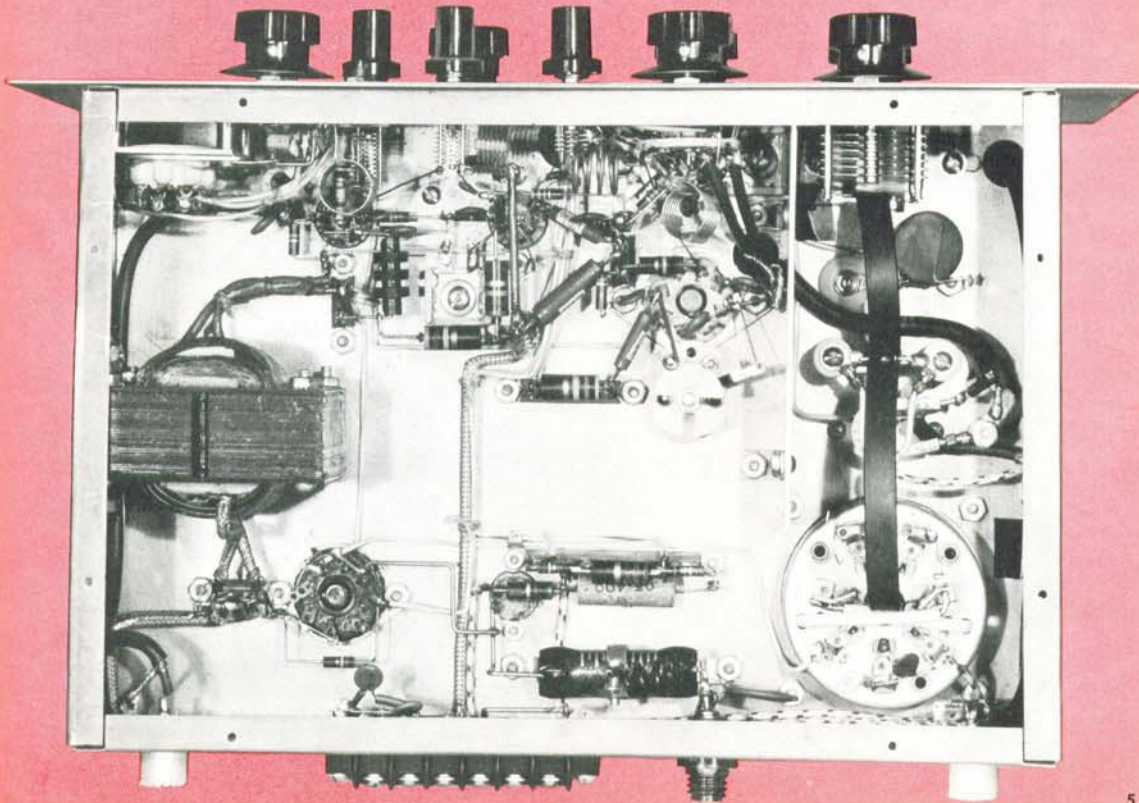

Fig. 5—Chassis bottom view.



$\frac{1}{8}$ -inch thick sheet aluminum $2\frac{7}{8} \times 5\frac{1}{4}$ inches separates the amplifier grid components from the rest of the under-chassis circuits. Grid circuit tuning capacitor C_{10} mounts on the chassis front. Half-wave grid tank circuit L_9 , made from 300-ohm flat twin lead, is soldered to lugs fastened to another pair of 1-inch high cone insulators at the point where it is tapped. The ends of this line connect to the grid terminals on the GL-829B socket and to the stator lugs on the grid tuning capacitor, C_{10} . Grid coil L_7 is soldered to another pair of solder lugs on these insulators. Link coil L_8 is fastened to an 8-32 x $1\frac{1}{2}$ -inch long machine screw that projects through the chassis for coupling adjustment. A hex-nut on this screw locks the adjustment after tuning the transmitter.

The two crystal octal sockets are positioned so that the crystal holders lie in a horizontal plane. They mount on a 2 x 3 x $\frac{1}{8}$ -inch thick aluminum plate which has two $1\frac{1}{4}$ -inch diameter and four No. 26 mounting holes drilled to match the chassis. These parts straddle the $1\frac{1}{4} \times 2\frac{1}{4}$ -inch chassis cutout on $\frac{3}{4}$ -inch long spacers slipped over the 6-32 x $1\frac{1}{4}$ -inch long fastening screws. Both the FT-243 and AX-2 type crystal holders will project far enough through the matching slot in the panel to be easily removed. A Mosley type 53 3-gang crystal multi-socket can be substituted if the access and mounting holes are changed accordingly. A *snap-in* cover also made from perforated sheet aluminum helps prevent radiation of 24-megacycle energy from the crystals. The two coaxial cable connectors, power terminal strip and high voltage terminal fasten along the rear side of the chassis, as shown in the bottom view, Fig. 5.

WIRING DETAILS

Shielded hook-up wire is used for all connections from the power connection strip to the parts terminal strips, filament transformer primary and heater leads to the tube sockets. The shield on these leads is grounded at each end and the center conductor on each wire is also by-passed to the shield at the power connection strip. Shortest possible leads are used for all RF and by-pass capacitor connections. Cathode pins 1, 4 and 6 on the GL-2E26 socket each have a separate by-pass capacitor to a chassis ground. Short lengths of RG-58/U coaxial cable are used for connections between the coaxial cable jacks, link coils and switches. Leads supplying plate and *screen* voltages to the 5763 and GL-2E26 should not be connected at this time. All 600-volt leads should have 2000-volt insulation and leads from beneath the chassis to S_3 were cabled. When the transmitter is mounted in a suitable table cabinet, further TVI precautions may be necessary only in areas where a fringe-level signal is received from a television station on channel 2.

ADJUSTMENT PROCEDURE

Before any tubes are placed in their sockets, all power should be applied to the transmitter and the socket voltages checked. Next, all tubes and your selection of crystals are inserted. A 144-megacycle range crystal is selected on S_1 , bandswitch S_2 is set in that position and meter selector switch S_3 is turned to position "A." Plate and *screen* voltage is applied temporarily to the 5763, but not to the GL-2E26 or GL-829B tubes. With crystal feedback capacitor C_2 set about 1 turn from maximum capacity, C_1 is rotated until the meter shows a grid current rise in the 5763 stage. Next, C_2 is turned slowly toward maximum capacity until oscillation stops, then toward minimum capacity until crystal oscillation again starts. Doubler tuning capacitor C_3 is adjusted for a sharp rise in 5763 grid current. After turning S_3 to position "B," C_4 , C_5 and spacing of the turns on L_3 are adjusted for maximum grid current on the GL-2E26, with C_4 tuning to resonance near minimum capacity.

To neutralize the GL-2E26, capacitor C_8 is adjusted until there is no fluctuation in grid current as plate tuning capacitor C_9 is rotated. If this stage will not neutralize with a straight lead from the socket screen terminal to C_8 , a small loop in this lead may be necessary. The plate and screen voltage lead to this tube is now connected and S_3 is moved to position "C." The turn spacing of L_5 is adjusted so that C_9 resonates with this coil near $\frac{1}{3}$ of maximum capacity. Link coil L_6 is now inserted at the end of L_5 attached to C_9 . After setting S_3 to position "D," C_{10} and L_8 are adjusted for maximum grid current on the GL-829B. Length of the L_9 twin lead is adjusted to tune with C_{10} near minimum capacity. Link coil L_6 is then cemented in place.

The GL-829B is now neutralized by checking the grid current fluctuation as neutralizing wires C_N are slowly bent away from the tube while tuning plate circuit capacitor C_{11} . On the test model, these wires were clipped off until neutralization was obtained with the wires close to the glass envelope, $1\frac{1}{2}$ inches above the ceramic socket wafer. Plate voltage is then applied to this tube and a suitable 50-ohm dummy load connected to coaxial output connector J_2 . Resonance near the minimum capacity setting of C_{11} should be established by adjusting the spacing of the L_{12} copper tubing by moving the supporting cone insulators in their fastening slots, shifting the tubing ends on the C_{11} stator lugs and changing the length of the flexible straps on the plate caps, if necessary. The tank circuit cover should be in place after each adjustment, as this added capacity to ground lowers the resonant frequency about 10 megacycles.

For 50-megacycle operation, S_1 and S_2 are set in that position, S_3 is turned back to position "A" and the plate and *screen* voltage is removed from the 5763 tube. The oscillator and doubler are re-tuned and output capacitor C_6 is set near maximum capacity. The 5763 stage is neutralized by adjusting C_5 for no grid current fluctuation when C_4 is rotated. Some adjustment of the 1-turn loop from C_5 to the tube socket may be necessary for complete neutralization. After again connecting plate and *screen* voltages to this stage, S_3 is set at position "D" and both C_4 and C_6 are adjusted for maximum grid current on the GL-829B. Sufficient driving power should be obtained with the same setting of L_8 used for 144 megacycles. Inductance of both L_7 and L_{10} is adjusted so that 50-megacycle resonance on C_{10} and C_{11} occurs near the maximum capacity settings. A strong third harmonic of the 50-megacycle output from the amplifier may result if the tank circuits are not adjusted in this manner. The 20,000-ohm adjustable *screen* voltage dropping resistor should be set to obtain 200 volts on pin 2 of the OB2 regulator tube when the amplifier is running at the normal 600-volt, 170-milliampere CW input.

The measured plate circuit efficiency of the GL-829B on 144 megacycles was 64% when the transmitter was fed into a laboratory-type RF wattmeter. Apparently due to the rather bulky tank circuits, the amplifier efficiency dropped to 60% on 50 megacycles. For comparison purposes, another GL-829B amplifier was constructed using conventional 50-megacycle tank circuits and driven from the same exciter. The measured efficiency of this amplifier was checked at 66%. This slight difference in efficiency will not be noticeable when the transmitter is put on the air. In conclusion, the saving in parts cost of being able to utilize this transmitter on two widely separated bands where normally separate units are used was considered to be well worth the slight compromise mentioned above. For final "dressing up," Johnson type 116-222-5 line-indicator dials were mounted on the controls shown in the cover view. Also used were 3 type 116-214-2 knobs which fit the $\frac{1}{8}$ -inch diameter shafts on the midget type "M" capacitors. Panel marking and dial decals label the controls and frequency ranges covered.

SWEEPING *the* SPECTRUM



If all of my Log Form QSL cards (see this column in Volume 10, Nos. 4 and 5 issues of G-E HAM NEWS, for details and illustration) that were printed in the first press run were placed in a single pile, the resulting stack of cards would equal the size of a radio amateur's "dream" antenna tower, almost 500 feet high!! The flood of orders we have received for these cards is whittling that pile down pretty fast. A surprising number of requests have arrived for 600, 900, 1200, 1500 and in one instance, 6600 cards!

If you have the need for an inexpensive QSL card on which you can copy information in the same order that it appears in your station log, simply write me at the Tube Department, General Electric Company, Schenectady 5, N. Y. Packages of 300 cards, or any multiple of that number, will be delivered to you, postpaid, for a remittance of one dollar per 300 cards. At this price, we cannot accept requests for C.O.D. shipment or billing at a later date. The above address applies only to radio amateurs in the United States, Canada, Alaska, Hawaii and the Panama Canal Zone. In all other countries, write: Lighthouse Larry, International General Electric Company, 570 Lexington Avenue, New York 22, N. Y.

Incidentally, before you write, check through your file of back issues of G-E HAM NEWS. If any are missing, just tell me which copies you need and I will gladly send them to you as long as my supply lasts.

One of the first orders for my Log Form QSL card was received from a true "Hamm" family. In fact, both the OM and XYL are "C. W. Hamms." I really mean Carl W. Hamm, W9DWH (Dad Works Hard) and Charlotte W. Hamm, WN9UNY (Until Next Year), of Milwaukee, Wisconsin. They also have an eight-year old junior op, Jeffrey C., who may be labelled, "Junior Class," when he gets his ham ticket. Carl works 7-megacycle CW and phone and 28-megacycle phone. Charlotte can be heard in the 7-megacycle novice band. They are now looking for a contact with W4-NYX, of Shelby, North Carolina. Why? He is Clyde W. Ham!

Does your basement-level radio shack suffer from excessive humidity that plays havoc with receiver and VFO calibration? A recent copy of the REA NEWS, published by the Saint Paul (Minnesota) Mobile Radio Club, suggests that you can help keep your equipment dried out by getting on the air daily! The main idea is to keep the temperature of the equipment or basement a few degrees above the dew point, below which condensation of water vapor in the air occurs. Placing a few light bulbs in your equipment cabinets may be all that's necessary to keep out the dampness. An electric de-humidifier also will do a good job. By all means, vent that automatic clothes dryer to the outside—some types release vast amounts of moisture into the air.

After recently receiving comments from a few fellows that they have been unable to buy the type 6CA5 audio power amplifier tube used in the HAM-SHACK INTERCOM described in the May-June, 1955 issue of G-E HAM NEWS, I decided that the situation needed checking into. Result—our receiving tube sales section says that there is not a large replacement demand for this tube and it may not be readily available. Fortunately, the electrical characteristics are similar to the more popular 6BF5, except for a lower power sensitivity. The only changes necessary to use this tube will be to reverse connections to pin 1 and 2 on the 6CA5 socket and change the lead from output transformer T₂ from pin 7 to pin 5.

I suppose that by now a number of these units may have been built using other output tubes that happened to be handy in the junk box. By applying the appropriate voltages, types 6AQ5, 6V6-GT or 6K6-GT might be used. Even a 6L6-GB might be your *bottle* if the local QRM is high!

I asked the editor the other day why most recent gear built for G-E HAM NEWS has included a small square of *do-it-yourself* perforated aluminum sheet. "Well," he said, "That particular type of aluminum has a pleasing decorative pattern, is easy to cut and bend with hand tools and makes a pretty good RF shield." Note that a complete shield of this material surrounds the GL-829B amplifier on the "Bonus 100" transmitter in this issue. Then he gave me a sneak preview of some of the equipment which is scheduled to appear in future issues of G-E HAM NEWS—and this material is used for shielding in several places. So, here's a tip straight from Lighthouse Larry. Keep a sheet of that stuff handy at your workbench if you intend to try your hand at some of our latest designs. The boss won't rest until he has used it all up!

The editor of one of the larger amateur radio club bulletins says that he is considering the possibilities of a stacked array of folded dipoles for 2400 MC. Want to know the source of the material? His 300-ohm feedline got caught in the power lawn mower.

Gang—just a reminder that the deadline for entering nominations in the Fourth Annual Edison Radio Amateur Award is January 3, 1956. Complete details were published on page one of the September and October issues of QST, September issue of CQ and on page 8 of the September-October issue of G-E HAM NEWS. Or, you can obtain a copy of the rules by dropping me a postcard. The award means national recognition and a nice cash bonus for the winner. Send those nominations in now to the Edison Award Committee, General Electric Company, Tube Department, Schenectady 5, N. Y.

—Lighthouse Larry

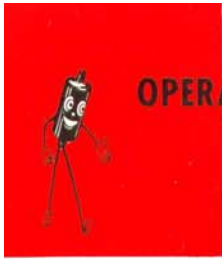

OPERATION CRYSTAL

Several interesting construction hints about the preparation of small to medium sized plastic boxes to house crystal radios have been passed along by L. B. Cebik, WIAPS, of Stratford, Connecticut. Their transparency, shock resistance and low cost make them almost ideal if the following precautions are observed.

When drilling holes in the plastic, small cracks may appear in that area. To avoid this, a wire or rod of the proper diameter is heated with a soldering iron or flame and pressed through the plastic. This method can also be used for wire leads that must pass through the case. Larger holes for control shafts can be cut with a razor blade. Instead of using bolts (and holes) to mount coil forms or small parts, cement them in place with household cement. Larger diameter coils can be wound directly on the outside or inside of the plastic box, with the turns cemented in place. Control knobs and terminals can be located on an unused side of the case.

"Where will your crystal set be when an emergency comes? On some forgotten shelf or buried in the junk box? Not mine!" —says H. G. Weist, Jr., K2AWA, of Schenectady, N. Y. "My crystal radio is patch-corded to the phono-input jack of the family television receiver. It is used almost daily to get news and other special radio programs from the local broadcast station. Being in constant use, I will have no trouble finding it and putting it to good use if and when the time comes—Remember—you can't use it if you can't find it!"

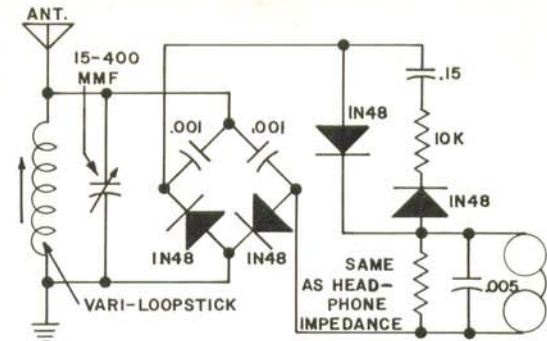

The bridge circuit detector plus diode network circuit shown above is your meat if your late rich Uncle Sparky bequeathed you a shoebox full of crystal diodes. Increased output was measured when the headphones were connected as shown over that obtained when the 'phones were connected across the output of the bridge detector. Drop me a line if you have a good explanation. Any old broadcast type variable capacitor can be used for tuning across the vari-loopstick coil, or you can substitute your favorite antenna input circuit for his, says Philip Benedict, ex-WN8KKR, of Columbus, Ohio.

All ideas submitted before December 1, 1955, will be eligible for publication in the OPERATION CRYSTAL Column. (See G-E HAM NEWS, Volume 10, No. 1.) Do not send in your model! Submitters of the three ideas published in each issue receive certificates for \$10 in G-E Electronic Tubes. Be sure to give complete coil-winding data for home-wound coils. All material submitted must be free from patent restrictions and becomes the property of G-E HAM NEWS.

—Danny Diode



G-E HAM NEWS

Available FREE from

G-E Electronic Tube Distributors

published bi-monthly by

TUBE DEPARTMENT

GENERAL  ELECTRIC

Schenectady 5, N. Y.

In Canada
Canadian General Electric Co., Ltd.
Toronto, Ontario

E. A. NEAL, W2JZK—EDITOR

NOVEMBER—DECEMBER, 1955

Printed in U.S.A.

VOL. 10—NO. 6